

This connector is a hybrid assembly with circuit cavities that accept two power contacts (circuits 1 and 2) and five signal contacts (circuits 3 through 7). The circuits are marked on the wire end of the connector. The connector mates with an interface by US Council for Automotive Research (USCAR).

This connector is not repairable. DO NOT use defective or damaged products. DO NOT re-use any contacts by removing the wire.

Reasons for reissue of this instruction sheet are provided in Revision Summary.

Contact Insertion

1 Ensure that all contacts are properly crimped.

The TPA must be in the pre-locked (as shipped) position before inserting any contacts into the circuit cavities. If it is not, move the TPA to the pre-locked position as follows:

— At the mating face of the connector, insert the tip of a small flat blade screwdriver or similar tool into the notch of the TPA; then gently rotate the tool until the handle rests on the cutout of the connector. See Figure 1.

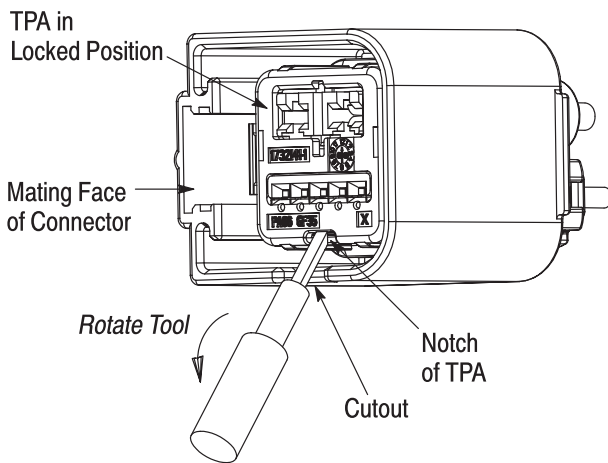

Figure 1

2 Align the contact with the appropriate circuit cavity at the wire end of the connector. Make sure to orient the contact as shown in Figure 2.

3 Insert the contact into the circuit cavity until there is an audible “click.” Lightly pull the wire to ensure that the contact is locked into place.

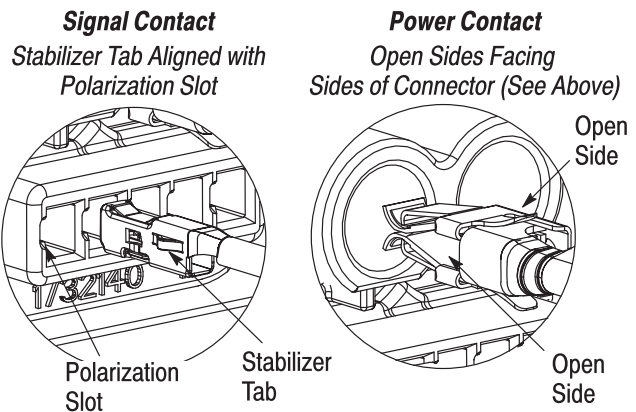
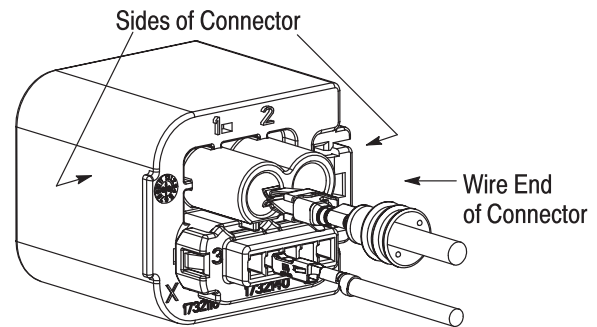

Figure 2

4 After all desired contacts are fully inserted, push the TPA into the housing until there is an audible “click.” See Figure 3. The TPA is closed (in the locked position). If there is resistance while pushing the TPA, make sure that every contact is fully inserted.

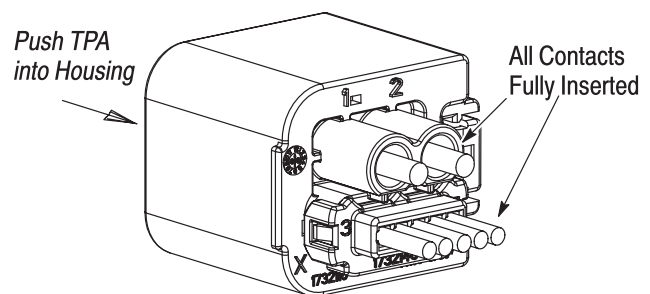

Figure 3

Mating

1 Align the key slots of the connector with the mating keys of the interface. See Figure 4.

2 Push the connector straight onto the interface until the latch engages the fin. There should be an audible “click.”

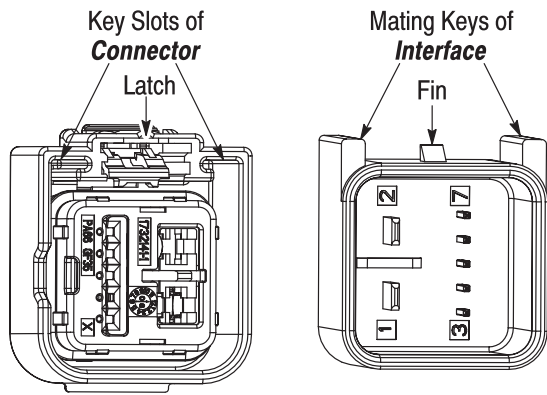

Figure 4

Unmating

Depress the primary connector latch, then simultaneously, pull the connector and interface straight apart. See Figure 5.

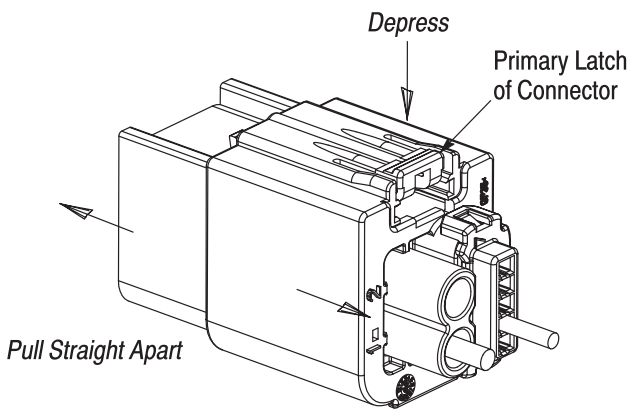

Figure 5

Contact Extraction

- 1** Before extracting any contacts, the connector and interface must be unmated. Refer to Unmating.
- 2** Before extracting any contacts, the TPA must be removed from the connector. Move the TPA to the pre-locked position as described in Step 1 of Contact Insertion. Then, continue to rotate the tool until the TPA is out of the connector.
- 3** At the mating face of the connector:
 - For signal contacts, insert the tip of Extraction Tool 3-1579007-6 into the circuit cavity of the contact to be removed, then push the tool in until it bottoms. See Figure 6.

— For power contacts, insert the tip of Extraction Tool 1308280-1 into the circuit cavity of the contact to be removed, then push the tool in until it bottoms. See Figure 6.

Then:

Hold the tool in place, grasp the wire of the contact, and *gently* pull the contact out of the housing.

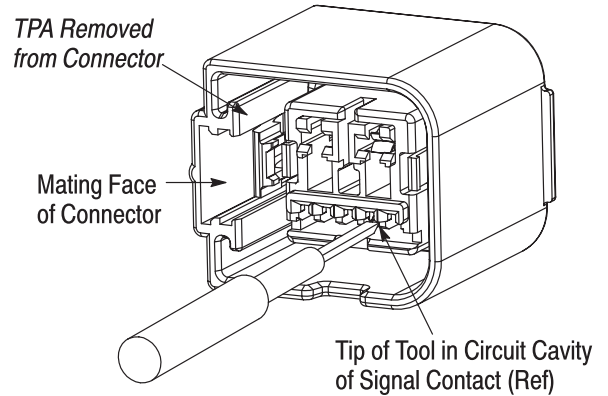

Signal Contact

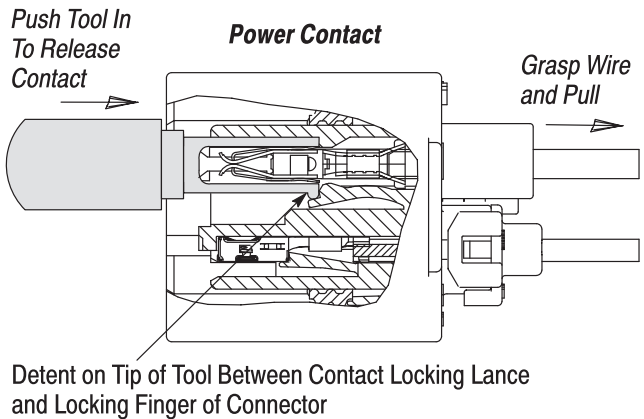
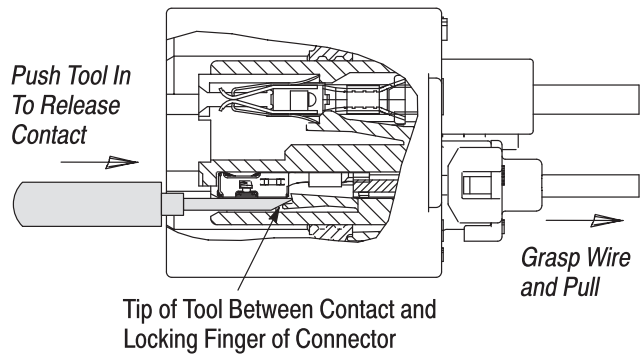

Figure 6

Revision Summary

- Corrected connector part number on page 2
- Removed old Tyco logo from figures